

# All Optical EX-OR Gate Based On Four Wave Mixing Non Linear Effect in Semiconductor Optical amplifier(SOA)

Saumya Saxena

Department of Electronics & communication, Saroj Institute of Technology & Management, GBTU, Lucknow, U.P, India  
Saxena.saumya07@gmail.com

**Abstract** — A novel approach towards the realization of all optical Ex-OR gate using all optical NOR gate, based on Semiconductor optical amplifier(SOA), has been presented in this paper, exploiting Four wave mixing(FWM), non linear effect in SOA's.

The design and simulation of the circuit has been described with the help of Optiwave software version 7.0 and have been optimized by measuring the output at different values of input parameters like input optical power, injection current and active region length of SOA. Here, in this paper the optimized output has been presented .Several approaches have already been suggested for designing all optical logic gates which includes cross gain modulation(XGM),cross phase modulation(XPM) and Machzehender interferometer (MZI) structure etc. In this paper we will use the idea to generate FWM signals by keeping two data pumps(A and b) frequencies fixed at 193Thz and 193.1Thz respectively, which will generate the FWM at 193.2Thz.

**Index Terms**— Four wave mixing(FWM), Cross gain modulation(XGM), cross phase modulation(XPM) , Semiconductor optical amplifier (SOA), variable optical attenuator(VOA), Band pass filter(BPF), EDFA and Fork(1x2)

## 1. INTRODUCTION

A non linear device called as semiconductor optical amplifier(SOA), emerged as a practical solution for all-optical signal processing function, where one signal has been controlled by the other signal.

SOA based optical signal processing devices can easily handle complex signal and process the data rates of upto 40Gb/s with much less power consumption of (1W), however modern high speed electronic equipment consumes much more power than 10kw and requires equivalent power to remove the heat generated by the equipment. Also all-optical SOA devices can readily be integrated to form an array of devices with smaller footprints. such kind of SOA based optical signal processing finds vast application in Telecommunication field. Especially, tasks such as wavelength conversion and signal regeneration are remarkable in telecom network.

All-optical signal processing devices is not a replacement of the electronic system, it just increases the effectiveness , capacity and flexibility of the next generation system in optoelectronics domain. In this paper ,design of all-optical Ex-or gate using optical NOR gate has been simulated and analyzed ,using a non-linear behavior called four wave mixing(FWM) in SOA.

FWM occurs when light of three different wavelengths is launched into a fiber, giving rise to a new wave (know as an idler), the

wavelength of which does not coincide with any of the others. FWM is a kind of optical parametric oscillation.

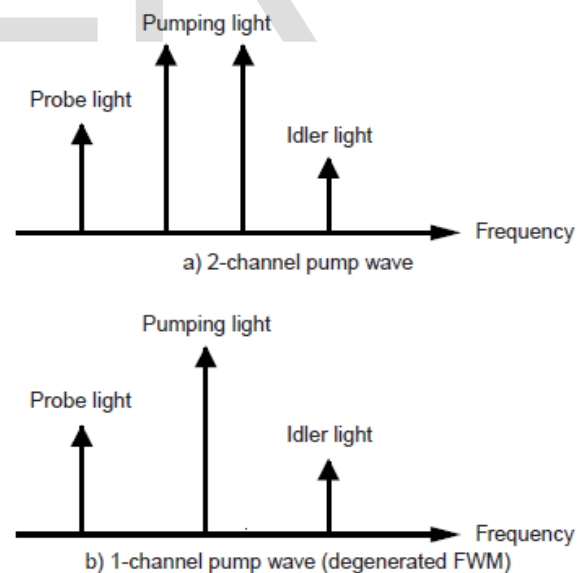

Above, figure shows four-wave mixing in the frequency domain. As can be seen, the light that was there from before launching, sandwiching the two pumping waves in the frequency domain, is called the probe light (or signal light). The idler frequency 'fidler' may then be determined by the equation:

This paper is broadly divided into three

sections. The first section shows the introduction about all-optical devices and SOA and its non-linear effects(FWM). Section 2<sup>1</sup>

describes the operation principle behind the design of all-optical EXOR gate and section 3 describes the simulation and its results.

## 2. OPERATION PRINCIPLE

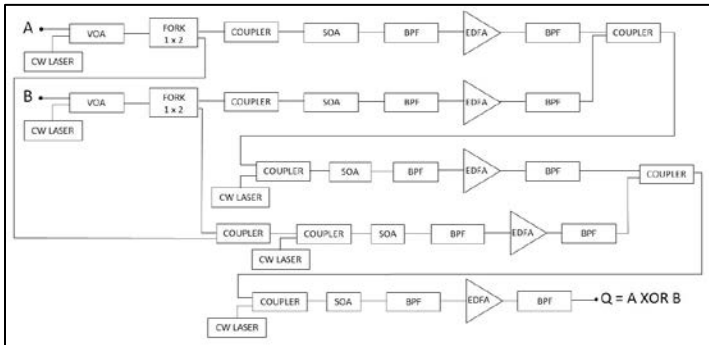

**Block Diagram Of All-Optical EXOR GATE using Optical NOR GATE**

In this design of optical EXOR gate using optical NOR gate, two data pumps(A & B) same as in NOR gate which carries data signal and five probe pumps(CW Laser) are used to generate the logic of XOR gate. Besides that two Forks (1x2) are used two connect the two data pumps simultaneously to the couplers as shown in the above block diagram. At each stage the intermediate inputs are coupled using a coupler to generate the logic of OR gate and then it is coupled with the probe pump(CW laser) to give the logic of NOR gate. The whole circuit comprises of five Optical NOR gates and if connected as shown in the above figure will give the output of XOR gate, i.e the output will be high if and only if only one of the input is high otherwise low.

The frequencies of data pumps and probe pump are taken as below. SOA injection current, transmitter input power and active region length of SOA are taken as variable in the design to get the optimum result, but for frequency domain analysis it has been fixed to describe the working principle i.e FWM and to present the optimized results in this paper. The values taken are as follows:

S.No.	Parameter	Value
1	fA	193THz
2	FB	193.1THz
3	Fcw laser	192.9THz

4	Output power of both the transmitters (A and B)	10dbm
---	---	-------

**Table1: Input Parameters**

S.No.	Parameter	Value
1	SOA Injection current	0.1A
2	Active region length of SOA	0.0001m

**Table 2 : SOA Parameters**

## 3. SIMULATION AND RESULTS

### 3.1 Simulation:-

Circuit of optical XOR gate designed on Optiwave software is shown in figure. The transmitter A and B is designed by combining the bit sequence generator and optical Gaussian pulse generator. The bit sequence can be given as input but here only one bit has been used to generate the logic. Optical Gaussian pulse generator generates the optical pulse corresponding to the given input bit of desired frequency and optical power.

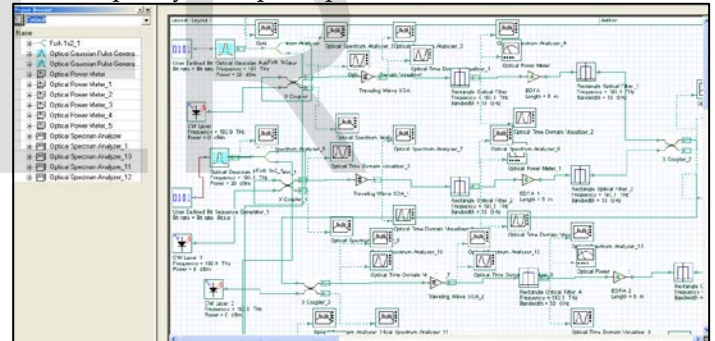

Simulation of EXOR gate on Optisystem software is done and is analyzed in the frequency domain by optical spectrum analyzer and in time domain by optical time domain analyzer, power meter is also used to measure the power at the output of every component. As we have already seen in the description of optical NOR gate that it is easy to describe the circuit operation and working principle by analyzing the circuit in frequency domain. And the generated logic can be obtained by measuring the power at the output, and optical time domain analysis is also important to see the shape of input and output signals.

### 3.2 Results:-

To verify the logic of EXOR gate which says the output will be high if and only if only one of the input is high otherwise low, the values of input optical power, injection current, and active region length of SOA are fixed to give the

• Saumya Saxena is currently pursuing M.Tech from Saroj Institute Of Technology & Management, Lucknow, affiliated to UPTU, India. Email : Saxena.saumya07@gmail.com

optimized results. When any of the inputs are high „1“ FWM is not generated at output of SOA as shown in figure and the whole power of CW laser is appeared at the output of the SOA and the output is considered to be high(logic 1). Otherwise low.

The outputs are analyzed in two domains, these are frequency domain and time domain. Optical Spectrum analyzer has been used for frequency domain analysis and Optical time domain visualizer is used for time domain analysis. Also optical power meter is used to check the output power levels.

The results obtained are as follows:

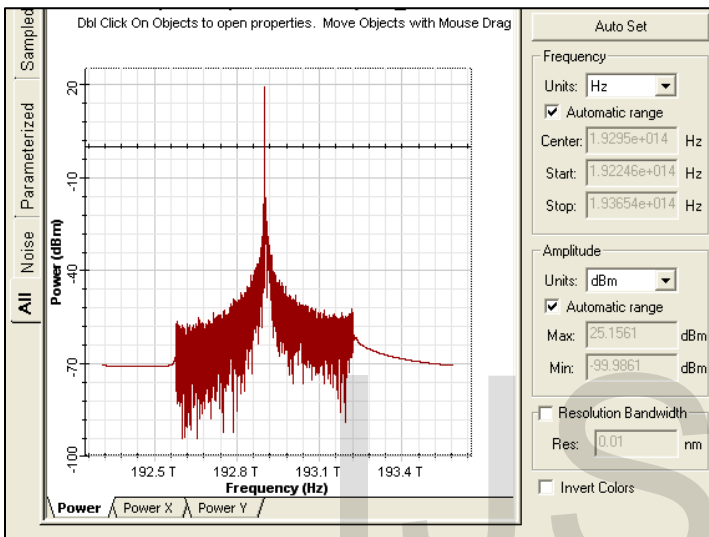

Fig 1: Spectrum analyzer at the output of SOA(No FWM generation) when either  $a=0, b=1$  or  $a=1, b=0$

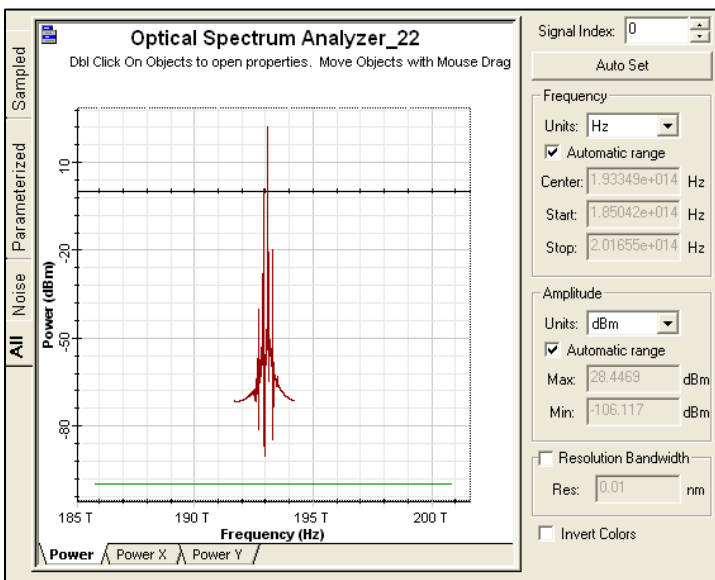

Fig 2: Spectrum analyzer at the output of SOA(FWM generation) when either  $a=1, b=1$

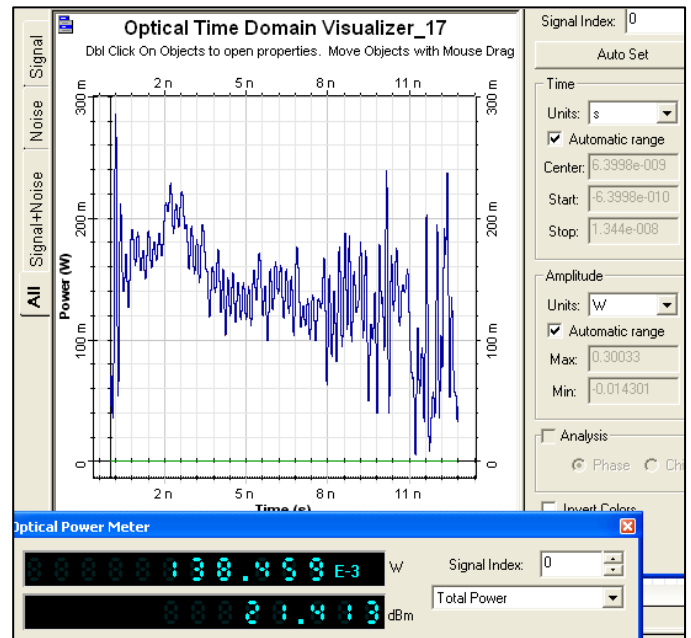

Fig 3: Output of time domain visualizer and power meter at  $A=0$  and  $B=0$

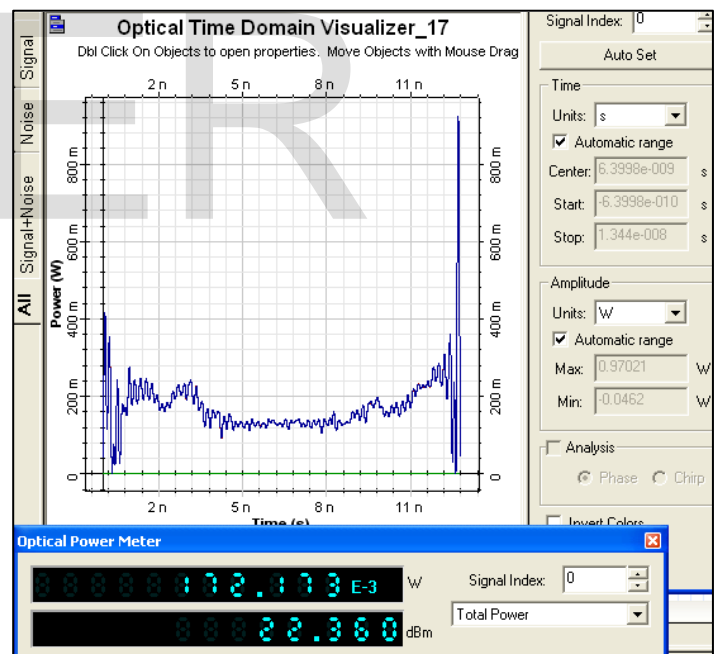

Fig 4: Output of time domain visualizer and power meter at  $A=0, B=1$

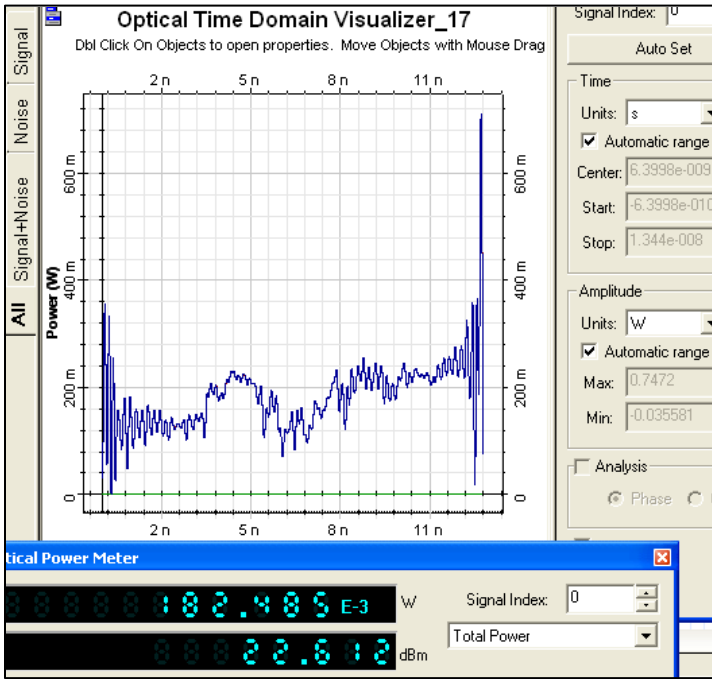

Fig 5: Output of time domain visualizer and power meter at A=1, B=0

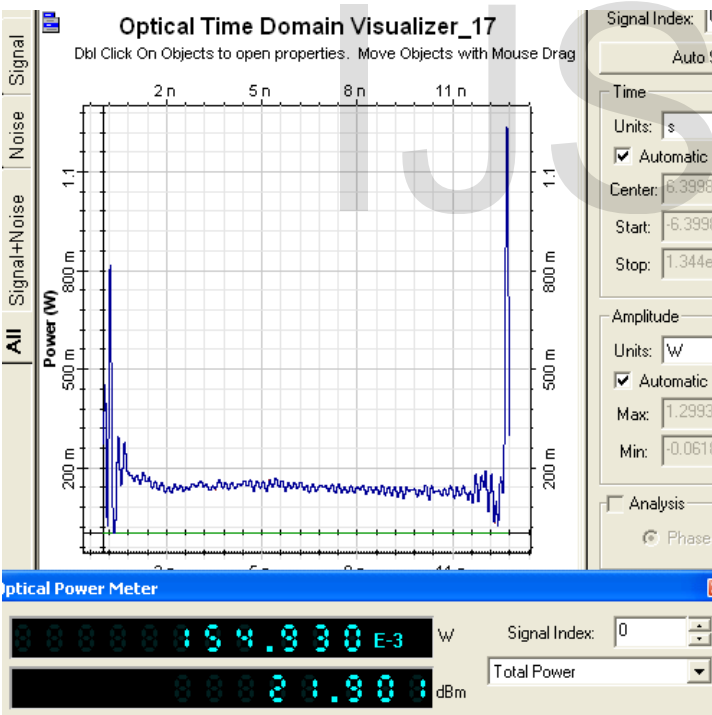

Fig 6: Output of time domain visualizer and power meter at A=1, B=1

Truth table obtained from the time domain analysis and power meter outputs corresponding to input signals are as below.

S.No.	A	B	Output Power (W)	Output power (dbm)	Logic
1	0	0	138.459e-3	21.413	0
2	0	1	172.173e-3	22.360	1
3	1	0	182.485e-3	22.612	1
4	1	1	154.930e-3	21.901	0

Table 3 : Truth table for optical EXOR gate

From the above truth table, it is clear that the output is high only when one of the input is high, otherwise low, which follows the logic of XOR gate .

#### 4. CONCLUSION

Simulation of All-optical EXOR gate using optical NOR gate has been successfully performed using Four wave mixing(FWM) property of SOA and the logic has been verified by checking the power levels at the output of SOA ,for all the possible input combinations. The great advantage of SOA gates is that they can be integrated to form gate arrays.

Since the optical gates are the basic elements for designing any combinational and sequential circuits. So thisAll optical EXOR gate design along with all other optical logic gates can be utilized to design the other circuits for switching and memory devices used in the next generation optical networks.

#### 5. ACKNOWLEDGEMENT

I would like to thank my family and especially my husband for their constant support.

#### 6. REFERENCES

1. Rekha Mehra, shikha Jaiswal, Hemant kumar dicit, "Ultrafast All-optical 4-bit digital encoders using differential phase modulation in semiconductor optical Amplifier-Machzehender interferometer configuration".--- <http://opticalengineering.spiedigitallibrary.org/> on 07/02/2014 Terms of Use: <http://spiedl.org/terms>, March 2013/Vol. 52(3)
2. Ankur saharia and Dr. Ritu sharma, "An approach for the relization of All optical NAND gate using Nonlinear effect in SOA" -- NNGT Journal :International Journal of Signal Processing and Imaging Engineering Volume 1 July 30,2014

3. Jing Wang, Gianluca Meloni, Gianluca Berrettini, Luca Poti, and Antonella Bogoni, "All Optical clocked flip-flops and binary counting operation using SOA based SR Latch and Logic Gates". IEEE journal of selected topics in quantum electronics 1077-260X © 2010 IEEE.
4. Zhihong li, Guifang li "Ultrahigh-speed reconfigurable logic gates based on four wave mixing in a semiconductor optical amplifier". IEEE photonics technology letters, vol. 18, no. 12, june 15, 2006.
5. B. Barber, C. R. Giles, V. Askyuk, R. Ruel, L. Stulz, and D. Bishop, "A fiber connectorized MEMS variable optical attenuator," IEEE Photonics Technol. Lett. 10, pp. 1262-1264 (1998).
6. X. M. Zhang, A. Q. Liu, C. Lu, and D. Y. Tang, "MEMS variable optical attenuator using low driving voltage for DWDM systems," Electron. Lett. 38, pp. 382-383 (2002).
7. T. Kawai, M. Koga, M. Okuno, and T. Kitoh, "PLC type compact variable optical attenuator for photonic transport network," Electron. Lett. 34, pp. 264-265 (1998).
8. M. Lenzi, S. Tebaldini, D. D. Mola, S. Brunazzi, and L. Cibinetto, "Power control in the photonic domain based on integrated arrays of optical variable attenuators in glass-on-silicon technology," IEEE J. Sel. Top. Quantum Electron. 5, pp. 1289-1297 (1999).
9. G. Z. Xiao, Z. Zhang, and C. P. Grover, "A variable optical attenuator based on a straight polymer-silica hybrid channel waveguide," IEEE Photonics Technol. Lett. 16, pp. 2511-2513 (2004).
10. C. Kerbage, R. S. Windeler, B. J. Eggleton, P. Mach, M. Dolinski, and J. A. Rogers, "Tunable devices based on dynamic positioning of micro-fluids in micro-structured optical fiber," Opt. Commun. 204, pp. 179-184 (2002).
11. C. Kerbage, A. Hale, A. Yablon, R. S. Windeler, and B. J. Eggleton, "Integrated all-fiber variable attenuator based on hybrid microstructure fiber," Appl. Phys. Lett. 79, pp. 3191-3193 (2004).
12. P. Mach, M. Dolinski, K. W. Baldwin, J. A. Rogers, C. Kerbage, R. S. Windeler, B. J. Eggleton, "Tunable microfluidic optical fiber," Appl. Phys. Lett. 80, pp. 4294-4296 (2004).
13. C. Grillet, P. Domachuk, V. Ta'eed, E. Magi, J. A. Bolger, B. J. Eggleton, L. E. Rodd, and J. Cooper-White, "Compact tunable microfluidic interferometer," Opt. Express 12, pp. 5440-5447 (2004).
14. Osamu Aso, Masateru Tadakuma and shu namiki "four-wave mixing in optical fibers and its applications", WP Team, Opto-technology Lab., R & D Div.
15. Mukesh K Bhongade, "A bidirectional link using optical circulators", National Center for Radio Astrophysics, Tata Institute of Fundamental Research, Giant Meterwave Radio Telescope, Khodad.(Pune).
16. Saumya Saxena, Shyamal Saxena, sadaf Z. rizvi, "Realization of all-optical NOR gate based on four wave mixing, non-linear effect in SOA", International Journal of Latest Trends in Engineering and Technology (IJLTET), Vol. 5 Issue 1 January 2015, ISSN: 2278-621X.

IJSER